

# Cutlass Fasteners, Inc.

83 Vermont Ave., Unit 6, Warwick, RI 02888  
 Tel: (401) 732-6333 Fax: (401) 732-6336  
 cutlass-studwelding.com

## Stud Welding...

- Fasteners
- Equipment
- Service

## ARC PDB WELD STUDS

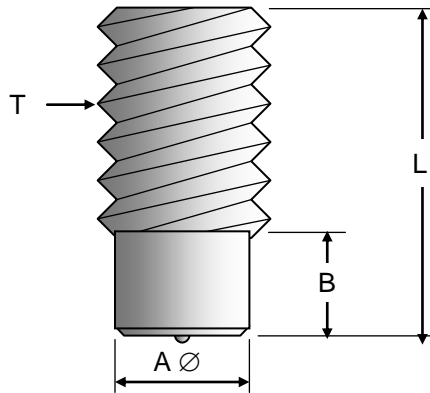

T (Thread)	A Ø	B	Ferrule
1/4-20	0.215	0.375	PDB-08
5/16-18	0.275	0.375	PDB-10
3/8-16	0.334	0.390	PDB-12
1/2-13	0.448	0.500	PDB-16
5/8-11	0.562	0.625	PDB-20
3/4-10	0.680	0.860	PDB-24

Thread Size	Material	Part No. Prefix	L (Length ± 0.015")													
			3/4	7/8	1.0	1.1/8	1.1/4	1.3/8	1.1/2	1.5/8	1.3/4	2.0	2.1/8	2.1/2	3.0	4.0
1/4-20 UNC	Mild Steel	3101-	0824	0828	0832	0836	0840	0844	0848	0852	0856	0864	0868	0880	0896	08128
	Stainless	3102-	0824	0828	0832	0836	0840	0844	0848	0852	0856	0864	0868	0880	0896	08128
5/16-18 UNC	Mild Steel	3101-	1024	1028	1032	1036	1040	1044	1048	1052	1056	1064	1068	1080	1096	10128
	Stainless	3102-	1024	1028	1032	1036	1040	1044	1048	1052	1056	1064	1068	1080	1096	10128
3/8-16 UNC	Mild Steel	3101-		1228	1232	1236	1240	1244	1248	1252	1256	1264	1268	1280	1296	12128
	Stainless	3102-		1228	1232	1236	1240	1244	1248	1252	1256	1264	1268	1280	1296	12128
1/2-13 UNC	Mild Steel	3101-			1632	1636	1640	1644	1648	1652	1656	1664	1668	1680	1696	16128
	Stainless	3102-			1632	1636	1640	1644	1648	1652	1656	1664	1668	1680	1696	16128
5/8-11 UNC	Mild Steel	3101-					2040	2044	2048	2052	2056	2064	2068	2080	2096	20128
	Stainless	3102-					2040	2044	2048	2052	2056	2064	2068	2080	2096	20128
3/4-10 UNC	Mild Steel	3101-						2444	2448	2452	2456	2464	2468	2480	2496	24128
	Stainless	3102-						2444	2448	2452	2456	2464	2468	2480	2496	24128

Part number example....3/8-16 X 1.1/2 MS PDB ARC STUD....3101- 1248

Studs 1/2" diameter and below will be 1/8" shorter after weld. Studs 5/8" diameter and larger will be 3/16" shorter after weld. All part numbers refer to length before weld.

Non-Stocked sizes and non-standard diameters and/or lengths are available by special order....minimum order quantities may apply.