

# Cutlass Fasteners, Inc.

83 Vermont Ave., Unit 6, Warwick, RI 02888  
 Tel: (401) 732-6333 Fax: (401) 732-6336  
 cutlass-studwelding.com

## Stud Welding...

- Fasteners
- Equipment
- Service

## LACING ANCHORS

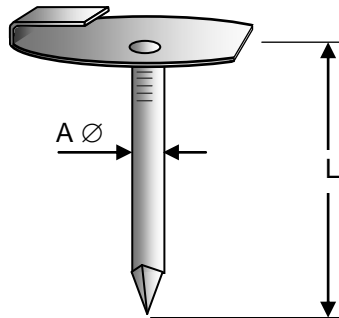

A Diameter	Material	Part No. Prefix	L (Length)			
			2.1/2	3.0	3.1/2	4.1/2
14 GA	Mild Steel	2331-	1480	1496	14112	14144
	Stainless Steel	2332-	1480	1496	14112	14144
12 GA	Mild Steel	2331-	1280	1296	12112	12144
	Stainless Steel	2332-	1280	1296	12112	12144

## QUILTING PINS

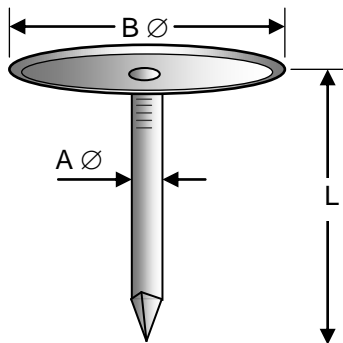

A Ø	B Ø
14 GA. (0.080")	1.3/16"
12 GA. (0.105")	1.3/16"

Diameter	Material	Part No. Prefix	L (Length)			
			1.0	1.1/2	2.1/2	4.1/2
14 GA	Stainless Steel	2342-	1432	1448	1480	14144
12 GA	Stainless Steel	2342-	1232	1248	1280	12144