

# Cutlass Fasteners, Inc.

83 Vermont Ave., Unit 6, Warwick, RI 02888  
 Tel: (401) 732-6333 Fax: (401) 732-6336  
 cutlass-studwelding.com

## Stud Welding...

- Fasteners
- Equipment
- Service

## CD INSULATION NAILS

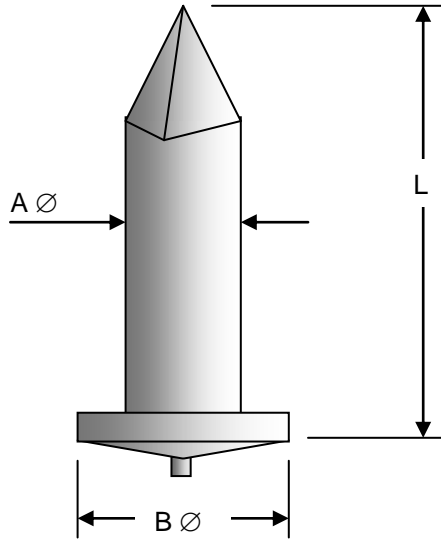

A Ø	B Ø (MS & SS)	B Ø (ALUM)
14 GA. (0.080")	0.175	0.220
12 GA. (0.105")	0.175	0.220
10 GA. (0.135")	0.220	0.250

Diameter	Material	Part No. Prefix	L (Length ± 0.015")													
			1/2	3/4	1.0	1.1/2	2.0	2.1/2	3.0	3.1/2	4.0	4.1/2	5.0	5.1/2	6.0	8.0
14 GA	Mild Steel	2301-														
	Stainless	2302-	1416	1424	1432	1448	1464	1480	1496							
	Aluminum	2303-														
12 GA	Mild Steel	2301-														
	Stainless	2302-	1216	1224	1232	1248	1264	1280	1296	12112	12128	12144	12160	12176	12192	12256
	Aluminum	2303-														
10 GA	Mild Steel	2301-														
	Stainless	2302-	1016	1024	1032	1048	1064	1080	1096	10112	10128	10144	10160	10176	10192	10256
	Aluminum	2303-														

- Stock Sizes
- Not Available

Part No. example....12 GA. x 2.1/2" long Stainless Steel....2302-1280

Non-Stocked sizes are available by special order.