

Cutlass Fasteners, Inc.

83 Vermont Ave., Unit 6, Warwick, RI 02888
 Tel: (401) 732-6333 Fax: (401) 732-6336
 cutlass-studwelding.com

Stud Welding...

- Fasteners
- Equipment
- Service

ARC DOUBLE POINTED PINS

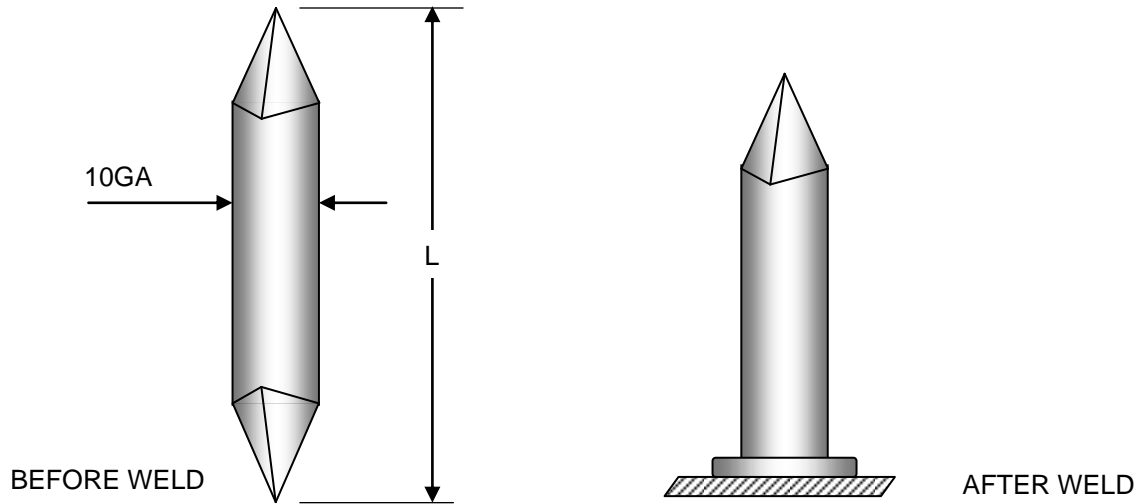

DIAMETER	MATERIAL	PART NO. PREFIX	"L" LENGTH (BEFORE WELD)							
			2.0	2.1/2	3.0	4.0	4.1/2	5.0	6.0	8.0
10GA	Mild Steel	3201								
	Stainless Steel	3202	1064	1080	1096	10128	10144	10160	10192	10256

Pins will be approximately 1/8" shorter after weld.

All pins use ferrule part. No FB-04.

Part no. example....10GA X 3.0 MS DP ARC PIN....3201-1232

Non-standard lengths are available by special order....minimum order quantities may apply.