

Cutlass Fasteners, Inc.

83 Vermont Ave., Unit 6, Warwick, RI 02888
 Tel: (401) 732-6333 Fax: (401) 732-6336
 cutlass-studwelding.com

Stud Welding...

- Fasteners
- Equipment
- Service

CD METRIC FLANGED WELD STUDS

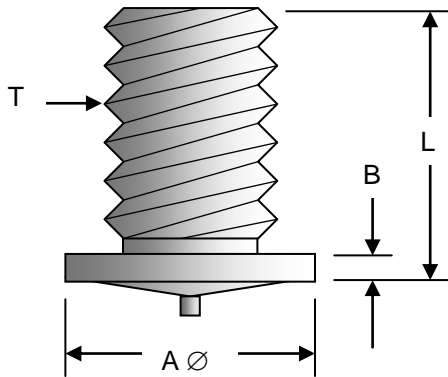

T (Thread)	A Ø	B
M3	4.3 – 4.7	0.9 max.
M4	5.3 – 5.7	0.9 max.
M5	6.3 – 6.7	0.9 max.
M6	7.3 – 7.7	0.9 max.
M8	9.3 – 9.7	1.0 max.
M10	11.3 – 11.7	1.0 max.

All dimensions in millimeters

Thread Size	Material	Part No. Prefix	L (Length ± 0.3mm)													
			6	8	10	12	15	16	20	25	30	35	40	45	50	60
M3	Mild Steel	2031-														
	Stainless	2032-	0306	0308	0310	0312	0315	0316	0320	0325	0330	0335	0340	0345	0350	0360
	Aluminum	2033-														
M4	Mild Steel	2031-														
	Stainless	2032-	0406	0408	0410	0412	0415	0416	0420	0425	0430	0435	0440	0445	0450	0460
	Aluminum	2033-														
M5	Mild Steel	2031-														
	Stainless	2032-	0506	0508	0510	0512	0515	0516	0520	0525	0530	0535	0540	0545	0550	0560
	Aluminum	2033-														
M6	Mild Steel	2031-														
	Stainless	2032-	0606	0608	0610	0612	0615	0616	0620	0625	0630	0635	0640	0645	0650	0660
	Aluminum	2033-														
M8	Mild Steel	2031-														
	Stainless	2032-	0806	0808	0810	0812	0815	0816	0820	0825	0830	0835	0840	0845	0850	0860
	Aluminum	2033-														
M10	Mild Steel	2031-														
	Stainless	2032-	1006	1008	1010	1012	1015	1016	1020	1025	1030	1035	1040	1045	1050	1060
	Aluminum	2033-														



Stock Sizes

Part No. example...M5 x 16 long Stainless Steel....2032-0516

All Studs Conform to DIN 32501/3

Non-Stocked sizes and non-standard diameters and/or lengths are available by special order....minimum order quantities may apply.