

Cutlass Fasteners, Inc.

83 Vermont Ave., Unit 6, Warwick, RI 02888
Tel: (401) 732-6333 Fax: (401) 732-6336
cutlass-studwelding.com

Stud Welding...

- Fasteners
- Equipment
- Service

PKM-1B CD WELD GUN MANUAL

MODEL	:	CLIPPER/CLASSIC	PINTO
PART NO.	:	PKM-1B	PKM-1B-P
SERIAL NO.	:		



PLEASE READ THIS OPERATION AND MAINTENANCE MANUAL
CAREFULLY BEFORE USING YOUR NEW CUTLASS STUD WELDER.

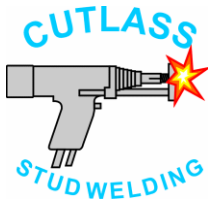

Cutlass Fasteners, Inc.

83 Vermont Ave., Unit 6, Warwick, RI 02888
Tel: (401) 732-6333 Fax: (401) 732-6336
cutlass-studwelding.com

Stud Welding...

- Fasteners
- Equipment
- Service

PKM-1B CD WELD GUN MANUAL

WARRANTY

The electrical and mechanical components of the Cutlass Stud Welders are thoroughly performance inspected prior to assembly in the Welder. The assembled Welder is completely performance checked. The Welder is delivered to you in perfect electro-mechanical condition. All parts used in the assembly of the Welder are fully warranted for a period of three (3) months from the date of delivery.

Under this warranty, the manufacturer reserves the right to repair or replace, at its option, defective parts which fail during the warranty period. Notice of any claim for warranty repair or replacement must be furnished to the manufacturer, by the purchaser, within five (5) days after the defect is first discovered. The manufacturer does not assume any liability for paying shipping costs, or for any labor or material furnished where such costs are not expressly authorized in writing.

We do not warrant the Cutlass Stud Welders, parts or accessories against failures resulting from misuse, abuse, improper installation, normal wear and tear, maladjustment or use not in accordance with the operating instructions furnished by the manufacturer. Cutlass shall never be liable for any consequential damages.

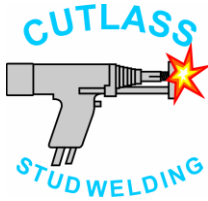

Cutlass Fasteners, Inc.

83 Vermont Ave., Unit 6, Warwick, RI 02888
Tel: (401) 732-6333 Fax: (401) 732-6336
cutlass-studwelding.com

Stud Welding...

- Fasteners
- Equipment
- Service

PKM-1B CD WELD GUN MANUAL

SUGGESTED SAFETY PRECAUTIONS

In any welding operation, it is the responsibility of the welder to observe certain safety rules to insure his personal safety and to protect those working near him.

Reference is directed without endorsement or recommendation, to ANSI Z49.1, Safety in Welding and Cutting, and to AWG Publication A6, 1-66 Recommended Safe Practices for Gas-Shielded Arc Welding.

1. Always treat electricity with respect. Under open circuit conditions, the welding machine output may be dangerous.
2. Do not work on live circuits and conductors. Disconnect the main power line before checking the machine or performing any maintenance operations.
3. Ensure the welding machine cabinet is properly grounded to a good electrical ground.
4. Do not stand in water or on damp floors while welding or weld in the rain. Avoid wearing wet or sweaty clothes when welding.
5. Do not operate with worn or poorly connected cables, and do not operate weld gun with loose cable connections. Inspect all cables frequently for insulation failures, exposed wires, loose connections and repair as needed.
6. Do not overload weld cables or continue to operate with hot cables.
7. Do not weld near flammable materials or liquids, in or near atmospheres, or on ducts carrying explosive gases.
8. Do not weld on containers which have held combustible or flammable materials, or on materials which give off flammable or toxic vapors when heated, without proper cleaning, purging, or inerting.
9. Ensure adequate ventilation is provided when welding in confined spaces.
10. Never look at the electrical arc without wearing eye shields.
11. Always use proper protective clothing, gloves etc. Never weld close to a bystander who is unaware of the possible dangers of ultraviolet light and weld splatter on their eyes.
12. Installation, servicing and trouble shooting should only be done by qualified personnel, familiar with this type of equipment.

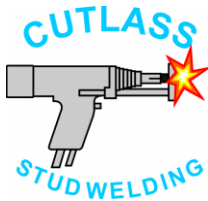

Cutlass Fasteners, Inc.

83 Vermont Ave., Unit 6, Warwick, RI 02888
Tel: (401) 732-6333 Fax: (401) 732-6336
cutlass-studwelding.com

Stud Welding...

- Fasteners
- Equipment
- Service

PKM-1B CD WELD GUN MANUAL

THE CAPACITOR DISCHARGE STUD WELDING PROCESS

HOW THE STUD WELD IS MADE:

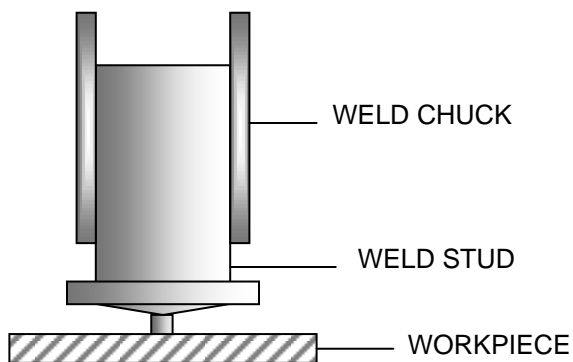

1. The stud is located on the spot to which it is to be welded.

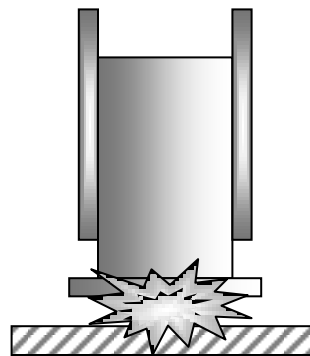

2. Stored energy is discharged through the precisely engineered weld tip at the base of the fastener.

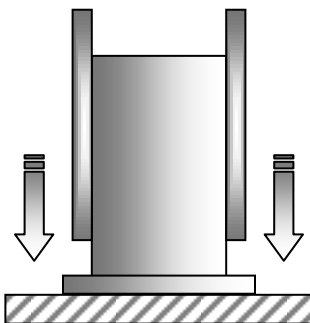

3. The stud is plunged into the molten weld pool, and fusion is achieved across the complete section of the weld.

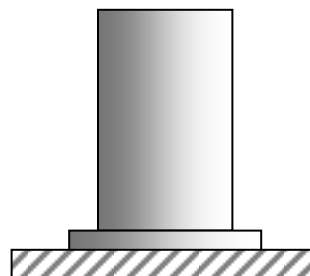

4. The weld gun is withdrawn leaving the fastener permanently welded to the workpiece.

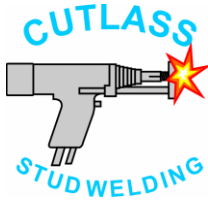

Cutlass Fasteners, Inc.

83 Vermont Ave., Unit 6, Warwick, RI 02888
 Tel: (401) 732-6333 Fax: (401) 732-6336
 cutlass-studwelding.com

Stud Welding...

- Fasteners
- Equipment
- Service

PKM-1B CD WELD GUN MANUAL

The electrical and mechanical parameters of the weld are set using the voltage control knob on the front of the welder and by adjusting the spring pressure of the welding gun.

ADJUSTING THE PKM-1B WELD GUN

The welding time depends on the speed of the stud as it moves forward into the molten welding pool. The speed is adjusted directly by changing the spring pressure. The greater the spring pressure, the shorter the welding time.

To adjust, use a coin or broad bladed screwdriver to turn the adjusting knob in the center of the back cap: Clockwise to increase spring pressure and Counterclockwise to reduce spring pressure. Set the spring pressure by observing the pointer in the window on the side of the weld gun. Do not force adjusting knob at limits of adjustment...damage to gun may occur if excess pressure is applied.

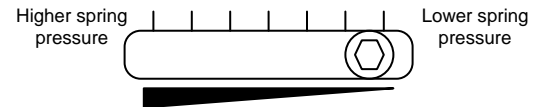
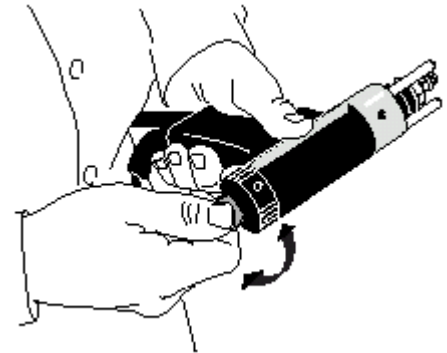

Exploded view of window scale on side of weld gun.

The gun is shipped from the factory in the 1-2 position. The suggested spring settings are shown below...

WORKPIECE MATERIAL	STUD MATERIAL AND DIAMETER														
	MILD STEEL **					STAINLESS STEEL					ALUMINUM ALLOY				
	#6	#8	#10	1/4	5/16	#6	#8	#10	1/4	5/16	#6	#8	#10	1/4	5/16
STEEL	1-2	1-2	1-2	1-2	1-2	1-2	1-2	1-2	1-2	1-2	-	-	-	-	-
STEEL GALVANIZED	1-2	1-2	1-2	1-2	-	1-2	1-2	1-2	1-2	1-2	-	-	-	-	-
STAINLESS STEEL	1-3	1-3	1-3	1-3	1-3	1-3	1-3	1-3	1-3	1-3	-	-	-	-	-
ALUMINUM ALLOY	-	-	-	-	-	-	-	-	-	-	4-6*	4-6*	4-6*	4-6*	-

* Aluminum studs can be welded using the contact method with limitations

** For Cupped Head Pins use spring setting at position #1

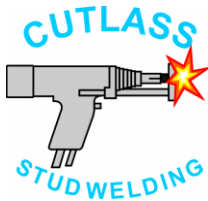

Cutlass Fasteners, Inc.

83 Vermont Ave., Unit 6, Warwick, RI 02888
 Tel: (401) 732-6333 Fax: (401) 732-6336
 cutlass-studwelding.com

Stud Welding...

- Fasteners
- Equipment
- Service

PKM-1B CD WELD GUN MANUAL

WELD GUN SETUP - standard weld studs

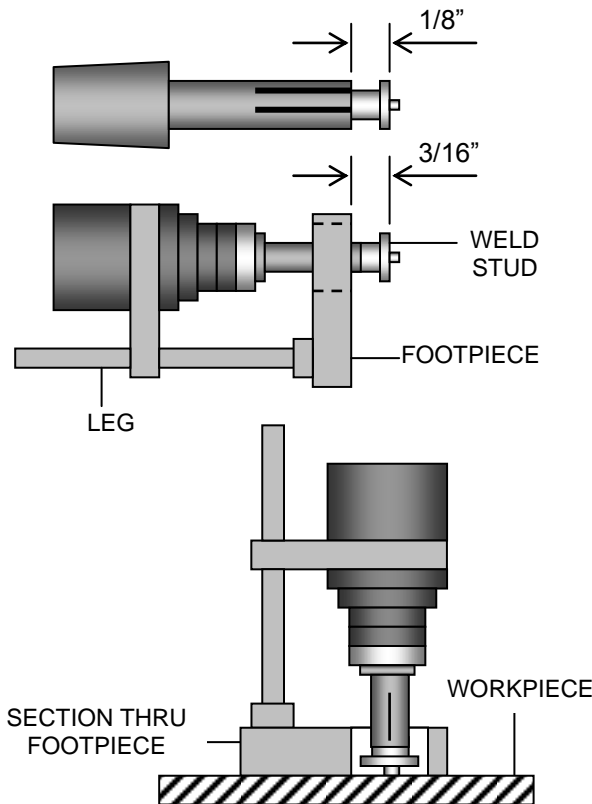

1. The weld chuck should be adjusted as shown. For longer studs, as much of the stud should be held as possible. This may require complete removal of the adjusting screw.
2. Seat weld chuck firmly in the front of weld gun and attach leg and footpiece assembly. Set leg depth so approximately 3/16" of stud/chuck protrudes beyond the footpiece.
3. Place the weld gun perpendicular to the workpiece as shown. Apply pressure to the gun so the footpiece lies firmly on the workpiece.
4. Hold gun steady and pull trigger when stud is in required position. After weld cycle withdraw gun from stud. Pull gun straight back so weld chuck is not damaged.
5. Inspect weld and adjust setting as required.

WELD GUN SETUP - insulation pins

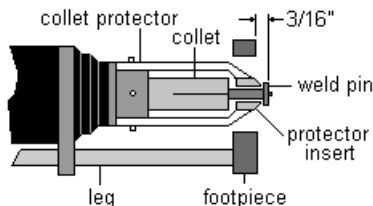

For standard weld pins up to 6" long

Assemble all accessories to gun as shown. Ensure front end of gun is centered through hole in footpiece and there is no binding of parts. Set protrusion of stud to approx. 3/16" so spring pressure will force stud into molten weld pool.

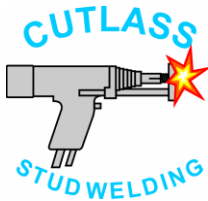

Cutlass Fasteners, Inc.

83 Vermont Ave., Unit 6, Warwick, RI 02888
 Tel: (401) 732-6333 Fax: (401) 732-6336
 cutlass-studwelding.com

Stud Welding...

- Fasteners
- Equipment
- Service

PKM-1B CD WELD GUN MANUAL

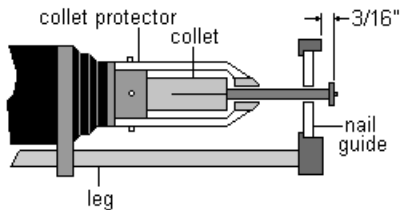

For all standard insulation pins over 6.1/2" long

Set up is as above except nail guide should be fitted to footpiece. Nail guide prevents long pins from bending or skidding during the weld. Again ensure pin is centered through nail guide and footpiece to prevent binding.

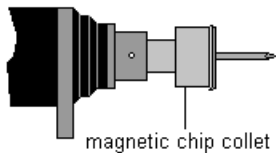

For cupped head and mini-cupped head insulation pins

Remove leg(s), footpiece, collet protector and collet from gun and store. Fit magnetic CHIP collet into spindle and tighten the two 10-32 holding screws in the gun spindle. Place cupped head pin onto magnetic collet ensuring pin is centered and well seated.

Set Pinto controller on power setting 5 or 6, push pin through insulation until contact is made with base material. Apply firm even pressure to gun (compress spring approx. 3/16"-1/4"). Hold gun steady and pull trigger. The spring in gun will force pin forward as the weld takes place.

TEST WELDING

Before making your first weld, check the ground clamp. It is essential that no power be lost through a poor connection. The surface under the ground should be free from oil, scale, grease and rust. The test should be on a piece of scrap material similar to the material to be used during actual production.

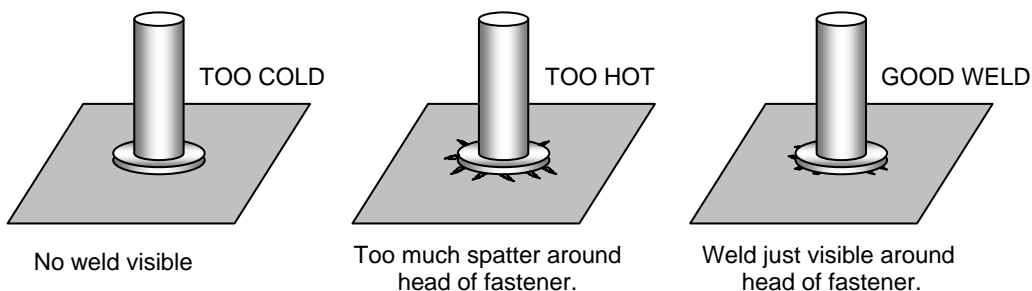

NOTE: IF WELD APPEARS COLD, DO NOT PLACE GUN ON WELDED STUD AND TRIGGER AGAIN. DAMAGE TO WELD CHUCK OR CONTROLLER WILL OCCUR.

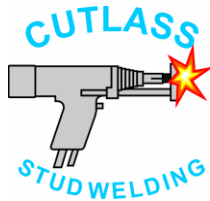

Cutlass Fasteners, Inc.

83 Vermont Ave., Unit 6, Warwick, RI 02888
Tel: (401) 732-6333 Fax: (401) 732-6336
cutlass-studwelding.com

Stud Welding...

- Fasteners
- Equipment
- Service

PKM-1B CD WELD GUN MANUAL

CAUSES OF POOR OR ERRATIC WELDS

1. Loose weld chuck – does not grip stud tightly.
2. Faulty or loose ground connections.
3. Dirty base material (oil, grease, rust etc).
4. Voltage too high or too low.
5. Broken or loose cables.
6. Gun binding – dirt in weld gun preventing free movement.
7. Leg and/or footpiece incorrectly set.
8. Use of center punch.
9. Weld cables coiled.

NOTE: The weld cables and ground cables should be laid out in a straight line or large loops. Poor weld quality may result if welding cables are closely coiled.

WELDER MAINTENANCE

Your Cutlass welder is designed for long service with minimum care. Ordinary common sense maintenance will keep it operating efficiently. Following are some tips on preventative maintenance:

1. Treat the welding and control cables with respect. Avoid sharp bends and kinks which may break the cables. Do not use the cables as a "tow-line" to move controller. Avoid damaging or straining the cables where they enter the gun or connectors.
2. Ensure unit vents are not obstructed, and that the unit is not covered while in use. Avoid overheating.
3. Keep the welding gun free of dust and dirt. Periodically clean weld splatter from front of gun.
4. The welder should not be placed in close proximity to any MIG or TIG welders, nor should the CD power source share a common power supply with MIG or TIG equipment. Similarly the main ground connection from the CD welder to the workpiece should not be linked in any way to MIG or TIG grounds.

FAILURE TO COMPLY COULD INVALIDATE YOUR WARRANTY

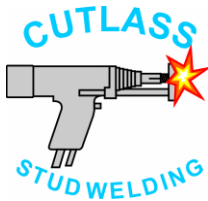

Cutlass Fasteners, Inc.

83 Vermont Ave., Unit 6, Warwick, RI 02888
 Tel: (401) 732-6333 Fax: (401) 732-6336
 cutlass-studwelding.com

Stud Welding...

- Fasteners
- Equipment
- Service

PKM-1B CD WELD GUN MANUAL

STANDARD ACCESSORIES

INCH

STUD SIZE	PART NUMBER
2-56UNC	015-509
12GA, 4-40UNC	602-467A
1/8	015-511
10GA, 6-32UNC	602-451A
8-32UNC	602-452A
#10, 3/16	605-101A
0.217	605-112
1/4	605-104A
5/16	605-105A
3/8	605-106A

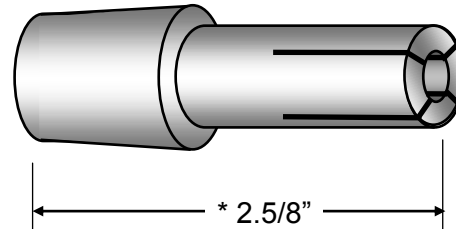

**STANDARD
ADJUSTABLE
WELD CHUCKS**

METRIC

STUD SIZE	PART NUMBER
3MM	605-111
4MM	602-423A
5MM	605-102
6MM	605-103
8MM	605-105A
10MM	605-106

* LONGER LENGTHS AVAILABLE ON REQUEST

CD FOOTPIECE

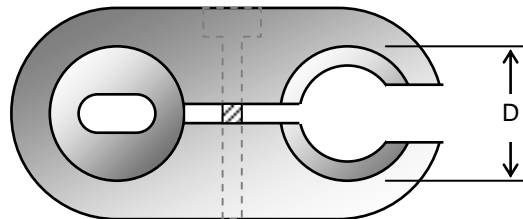

SIZE	'D' DIA.	PART NO.
SMALL	7/8"	023-252
MEDIUM	1.160"	023-252M

DESCRIPTION	PART NO.
JIG LOCATING BUSH D = 7/8"	650-691
NAIL GUIDE D = 7/8"	601-350
CHUCK DRIFT	000-374
SPARK SHIELD, SML. D = 1.16", A = 3/16"	999-013
SPARK SHIELD, LGE. D = 1.16", A = 1/2"	999-018

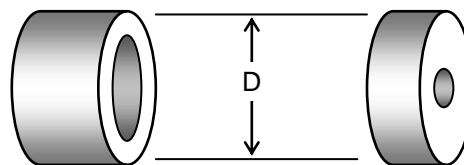

NAIL GUIDE

JIG LOCATING BUSH



CHUCK DRIFT

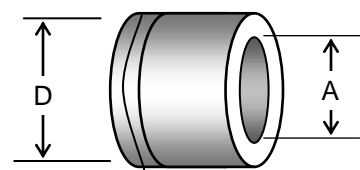

SPARK SHIELD

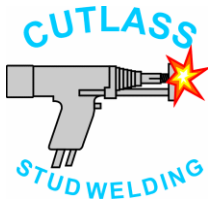

Cutlass Fasteners, Inc.

83 Vermont Ave., Unit 6, Warwick, RI 02888
 Tel: (401) 732-6333 Fax: (401) 732-6336
 cutlass-studwelding.com

Stud Welding...

- Fasteners
- Equipment
- Service

PKM-1B CD WELD GUN MANUAL

STANDARD INSULATION ACCESSORIES

B COLLETS

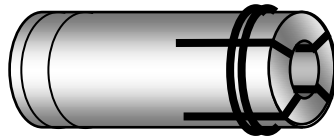

COLLET SIZE	PART NUMBER
14GA	669-232
12GA, #4	669-219
10GA, #6	669-220
3/16, #10	669-216

COLLET PROTECTOR

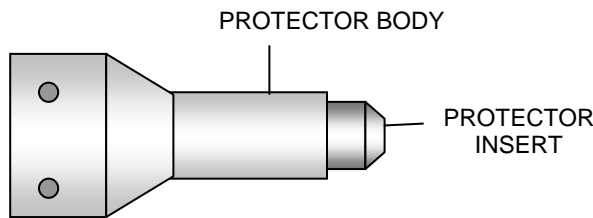

DESCRIPTION	PART NUMBER
BODY ONLY	028-836
12GA INSERT	028-834
10GA INSERT	028-835

FOOTPIECE

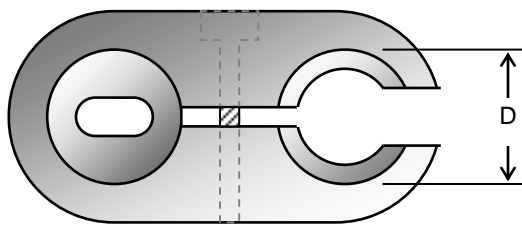

DESCRIPTION	PART NUMBER
FOOTPIECE S/L SMALL D=7/8"	023-252
FOOTPIECE S/L MEDIUM D=1.16"	023-252M

NAIL GUIDE

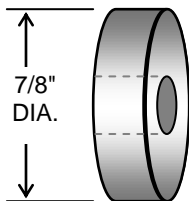

SPARK SHIELD

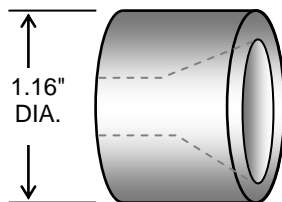

DESCRIPTION	PART NUMBER
NAIL GUIDE	601-350
SPARK SHIELD	999-013

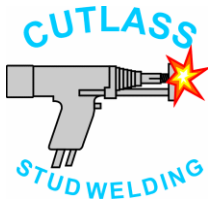

Cutlass Fasteners, Inc.

83 Vermont Ave., Unit 6, Warwick, RI 02888
 Tel: (401) 732-6333 Fax: (401) 732-6336
 cutlass-studwelding.com

Stud Welding...

- Fasteners
- Equipment
- Service

PKM-1B CD WELD GUN MANUAL

PKM-1B GUN PARTS

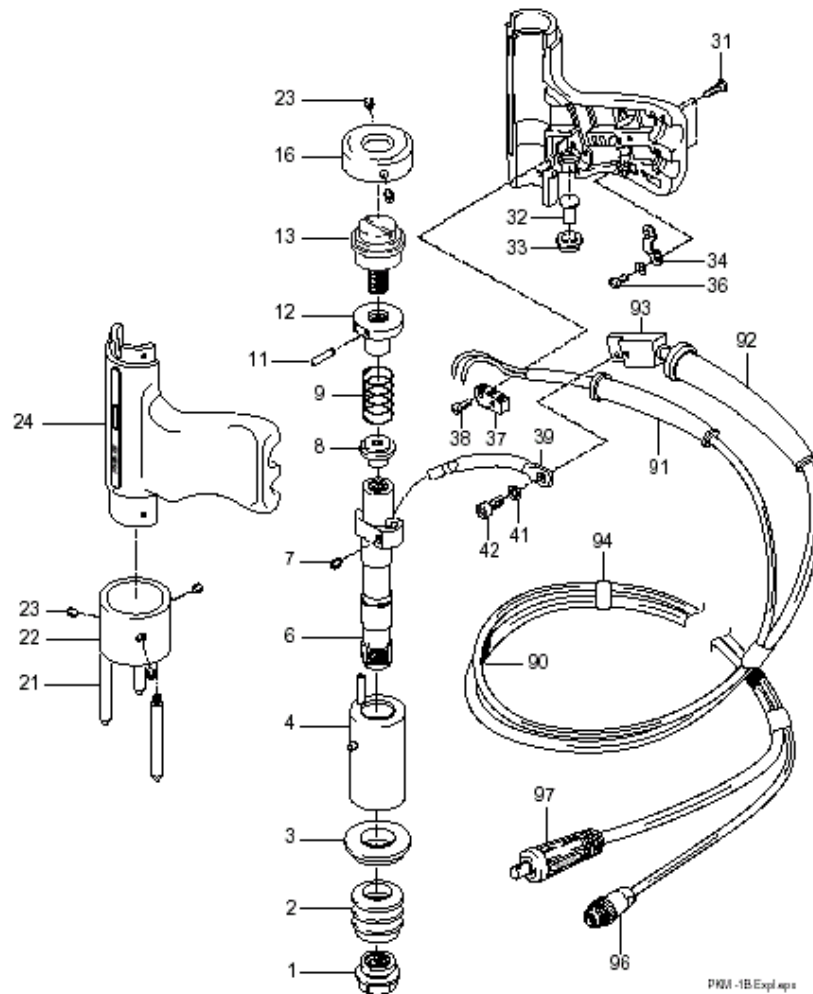

ALTERNATE PARTS...

ITEM	PART NO.	DESCRIPTION	QTY
1A	80-40-1741	B COLLET ADAPTOR	1
22A	80-40-1739	SINGLE LEG FACEPLATE (fitted as standard)	1
22B	80-40-1113	TWIN LEG FACEPLATE	1
96	999-136	CONTROL PLUG (Signus Only)	1
97A	000-573	WELD PLUG (Pinto Only)	1
97B	650-669	WELD PLUG (Signus Only)	1

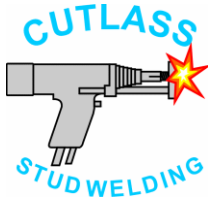

Cutlass Fasteners, Inc.

83 Vermont Ave., Unit 6, Warwick, RI 02888
 Tel: (401) 732-6333 Fax: (401) 732-6336
cutlass-studwelding.com

Stud Welding...

- Fasteners
- Equipment
- Service

PKM-1B CD WELD GUN MANUAL

PKM-1B GUN PARTS

ITEM	PART NO.	DESCRIPTION	QTY
	PKM-1B	COMPLETE CLIPPER PKM-1B	1
1	80-40-1738	TAPER CHUCK ADAPTOR	1
2	80-40-1097	BELLOWS	1
3	80-40-1023	INSULATING BUSH	1
4	80-40-1020	GUIDE BUSH	1
6	80-40-1740	SPINDLE	1
7	80-15-1011	M5 X 8 SOC. HD. SCREW	1
8	80-40-1027	SPRING PLATE	1
9	80-40-1031	MAIN SPRING	1
11	80-15-1022	M3 X 12 SOC. HD. SCREW	1
12	80-40-1015	ADJUSTING NUT	1
13	80-40-1603	SPRING ADJUSTING SCREW	1
16	80-40-1028	BACK CAP	1
21	80-40-1012	TRIPOD LEG	3
22	80-40-1013	TRIPOD FACEPLATE	1
23	80-15-1010	M5 X 4 SOC. HD. SCREW	1
24	80-40-1602	GUN BODY (TOP & BOTTOM)	1
31	80-10-1013	HANDLE SCREW	3
32	80-40-1016	TRIGGER BUTTON	1
33	80-40-1017	TRIGGER SLEEVE	1
34	80-10-1015	CABLE CLIP	1
36	80-15-1061	M2.5 X 8 SCREW	2
37	80-50-1013	TRIGGER SWITCH	1
38	80-15-1015	M2.0 X 10	2
39	80-72-1012	INTERNAL WELD CABLE	1
41	80-15-1016	M4 LOCK WASHER	1
42	80-15-1012	M4 X 8 SOC. HD. CAP SCREW 1	1
90	80-72-1039	WELD/CONTROL CABLE (16FT.)	1
91	80-10-1011	CONTROL CABLE SLEEVE	1
92	80-10-1013	WELD CABLE SLEEVE	1
93	80-35-1134	CABLE CONNECTING BLOCK	1
94	600-627	CABLE SLEEVE	1
96	000-594P	CONTROL PLUG C/M	1
97	000-568	WELD PLUG C/M	1